



Can you recall?

1. Do you recall that the flow of charged particles in a conductor constitutes a current?
2. An electric current in a metallic conductor such as a wire is due to flow of electrons, the negatively charged particles in the wire.
3. What is the role of the valence electrons which are the outermost electrons of an atom?

11.1 Introduction:

The valence electrons become de-localized when a large number of atoms come together in a metal. These are the conduction electrons or free electrons constituting an electric current when a potential difference is applied across the conductor.

11.2 Electric current :

Consider an imaginary gas of both negatively and positively charged particles. Fig. 11.1 shows the negatively and positively charged particles flowing randomly in various directions across a plane P. In a time interval t , let the amount of positive charge flowing in the forward direction be q^+ and the amount of negative charge flowing in the forward direction be q^- .

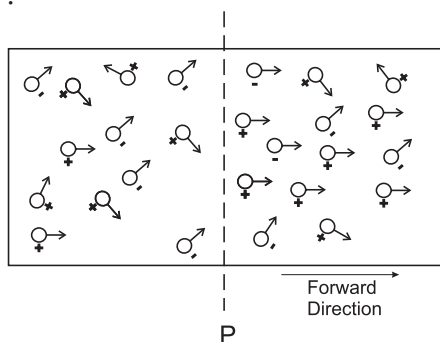

Fig. 11.1: Flow of charged particles.

Thus the net charge flowing in the forward direction is $q = q^+ - q^-$. For a steady flow, this quantity is proportional to the time t . The ratio $\frac{q}{t}$ is defined as the current I .

$$I = \frac{q}{t} \quad \text{--- (11.1)}$$

SI unit of the current is ampere (A), that of the charge and time is coulomb (C) and second (s) respectively.

Let I be the current varying with time. Let Δq be the amount of net charge flowing across

the plane P from time t to $t + \Delta t$, i.e. during the time interval Δt . Then the current is given by

$$I(I) = \lim_{\Delta t \rightarrow 0} \frac{\Delta q}{\Delta t} \quad \text{--- (11.2)}$$

Here, the current is expressed as the limit of the ratio $\Delta q / \Delta t$ as Δt tends to zero.

The current during lightning could be as high as 10,000 A, while the current in the house hold circuit could be of the order of a few amperes. Currents of the order of a milliampere (mA), a microampere (μA) or a nanoampere (nA) are common in semiconductor devices.

11.3 Flow of current through a conductor :

A current can be generated by positively or negatively charged particles. In an electrolyte, both positively and negatively charged particles take part in the conduction. In a metal, the free electrons are responsible for conduction. These electrons flow and generate a net current under the action of an applied electric field. As long as a steady field exists, the electrons continue to flow in the form of a steady current. Such steady electric fields are generated by cells and batteries.



Do you know ?

Sign convention : The direction of the current in a circuit is drawn in the direction in which positively charged particles would move, even if the current is constituted by the negatively charged particles, electrons, which move in the direction opposite to that of the electric field. We use this as a convention.

11.4 Drift speed :

Imagine a copper rod with no current flowing through it. Fig 11.2 shows the schematic of a conductor with the free electrons

in random motion. There is no net motion of these electrons in any direction. If electric field is applied along the length of the copper rod, and a current is set up in the rod, these electrons still move randomly, but tend to 'drift' in a particular direction. Their direction is opposite to that of the applied electric field.

Direction of electric field : Direction of an electric field at a point is the direction of the force on the test charge placed at that point.

The electrons under the action of the applied electric field drift with a drift speed V_d . The drift speed in a copper conductor is of the order of 10^{-4} m/s- 10^{-5} m/s, whereas the electron random speed is of the order of 10^6 m/s.

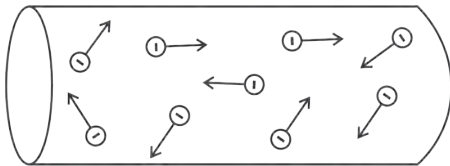

Fig. 11.2: Free electrons in random motion inside the conductor.

How is the current through a conductor related to the drift speed of electrons? Figure 11.3 shows a part of conducting wire with its free electrons having the drift speed V_d in the direction opposite to the electric field \vec{E} .

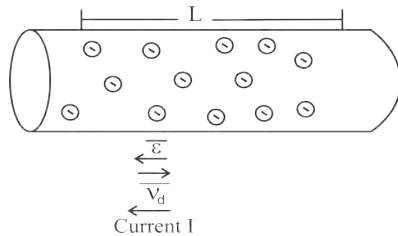

Fig. 11.3: Conducting wire with the applied electric field.

It is assumed that all the electron move with the same drift speed V_d and that, the current I is the same throughout the cross section (A) of the wire. Consider the length L of the wire. Let n be the number of free electrons per unit volume of the wire. Then the total number of electrons in the length L of the conducting wire is nAL . The total charge in the length L is,

$$q = n A L e \quad \text{--- (11.3)}$$

where e is the electron charge.

This is total charge that moves through any cross section of the wire in a certain time interval t ,

$$t = \frac{L}{V_d} \quad \text{--- (11.4)}$$

From the Eq. (11.1), and Eq. (11.3), the current

$$I = \frac{q}{t} = \frac{n A L e}{L/V_d} = n A V_d e \quad \text{--- (11.5)}$$

Hence

$$V_d = \frac{I}{n A e} = \frac{J}{n e} \quad \text{--- (11.6)}$$

where $J = I/A$ is current density. J is uniform over the cross sectional area A of the wire. Its unit is A/m^2

$$\text{Here, } J = \frac{I}{A} \quad \text{--- (11.7)}$$

From Eq. (11.6),

$$\vec{J} = (n e) \vec{V}_d \quad \text{--- (11.8)}$$

For electrons, $n e$ is negative and \vec{J} and \vec{V}_d have opposite directions, \vec{V}_d is the drift velocity.

Example 11.1: A metallic wire of diameter 0.02m contains 10^{28} free electrons per cubic meter. Find the drift velocity for free electrons, having an electric current of 100 amperes flowing through the wire.

(Given : charge on electron = $1.6 \times 10^{-19}C$)

Solution: Given

$$e = 1.6 \times 10^{-19} C$$

$$n = 10^{28} \text{ electrons/m}^3$$

$$D = 0.02m \quad r = D/2 = 0.01m$$

$$I = 100 A$$

$$V_d = \frac{J}{n e} = \frac{I}{n A e}$$

where A is the cross sectional area of the wire.

$$A = \pi r^2 = 3.142 \times (0.01)^2$$

$$= 3.142 \times 10^{-4} m^2$$

$$V_d = \frac{100}{3.142 \times 10^{-4} \times 10^{28} \times 1.6 \times 10^{-19}}$$

$$= \frac{10^{2+4-9}}{5.027}$$

$$V_d = 10^{-3} \times 0.1989 = 1.9 \times 10^{-4} m/s$$

Example 11.2: A copper wire of radius 0.6 mm carries a current of 1A. Assuming the current to be uniformly distributed over a cross sectional area, find the magnitude of current density.

Solution: Given

$$r = 0.6 \text{ mm} = 0.6 \times 10^{-3} \text{ m}$$

$$I = 1 \text{ A}$$

$$J = ?$$

Area of copper wire = πr^2

$$= 3.142 \times (0.6)^2 \times 10^{-6}$$

$$= 3.142 \times 0.36 \times 10^{-6}$$

$$= 1.1311 \times 10^{-6} \text{ m}^2$$

$$J = \frac{I}{A} = \frac{1}{1.1311 \times 10^{-6}}$$

$$J = 0.884 \times 10^6 \text{ A/m}^2$$

11.5 Ohm's law :

The relationship between the current through a conductor and applied potential difference was first discovered by German scientist George Simon Ohm in 1828 AD. This relationship is known as Ohm's law.

It states that "The current I through a conductor is directly proportional to the potential difference V applied across its two ends provided the physical state of the conductor is unchanged".

The graph of current versus potential difference across the conductor is a straight line as shown in Fig. 11.4

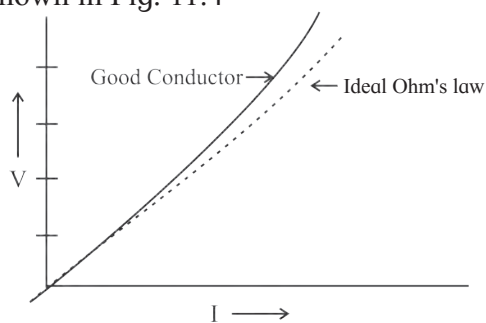

Fig. 11.4: I-V curve for a conductor.

In general, $I \propto V$

$$\text{or } V = IR \quad \text{or } R = \frac{V}{I}, \quad \text{--- (11.9)}$$

where R is a proportionality constant and is called the resistance of the conductor. The unit of resistance is ohm (Ω),

$$1\Omega = \frac{1 \text{ volt}}{1 \text{ ampere}}$$

If potential difference of 1 volt across a conductor produces a current of 1 ampere through it, then the resistance of the conductor is 1Ω .

Reciprocal of resistance is called conductance.

$$C = \frac{1}{R} \quad \text{--- (11.10)}$$

The unit of conductance is siemens or $(\Omega)^{-1}$

Example 11.3: A Flashlight uses two 1.5V batteries to provide a steady current of 0.5A in the filament. Determine the resistance of the glowing filament.

Solution:

$$R = \frac{V}{I} = \frac{3}{0.5} = 6.0\Omega$$

\therefore Resistance of the glowing filament is 6.0Ω .

Physical origin of Ohm's law :

We know that electrical conduction in a conductor is due to mobile charge carriers, the electrons. It is assumed that these conduction electrons are free to move inside the volume of the conductor. During their random motion, electrons collide with the ion cores within the conductor. It is assumed that electrons do not collide with each other. These random motions average to zero. On the application of an electric field \vec{E} , the motion of the electrons is a combination of the random motion of electrons due to collisions and that due to the electric field \vec{E} . The electrons drift under the action of the field \vec{E} and move in a direction opposite to the direction of the field \vec{E} .

Consider an electron of mass m subjected to an electric field \vec{E} . The force experienced by the electron will be $\vec{F} = e\vec{E}$. The acceleration experienced by the electron will then be

$$\vec{a} = \frac{e\vec{E}}{m} \quad \text{--- (11.11)}$$

The type of collision the conduction electrons undergo is such that the drift velocity attained before the collision has nothing to do with the drift velocity after the collision. After the collision, the electron will move in random direction, but will still drift in the direction opposite to \vec{E} .

Let τ be the average time between two successive collisions. Thus on an average, the

electrons will acquire a drift speed $V_d = a\tau$, where a is the acceleration given by Eq (11.11). Also, at any given instant of time, the average drift speed of the electron will also be $V_d = a\tau$. From Eq. (11.11),

$$V_d = a\tau = \frac{eE\tau}{m} \quad \text{--- (11.12)}$$

From the Eq. (11.6) and Eq. (11.12),

$$V_d = \frac{J}{ne} = \frac{eE\tau}{m} \quad \text{--- (11.13)}$$

which gives

$$E = \left(\frac{m}{e^2 n \tau} \right) J \quad \text{--- (11.14)}$$

or, $E = \rho J$, where ρ is the resistivity of the material and

$$\rho = \frac{m}{ne^2 \tau} \quad \text{--- (11.15)}$$

For a given material, m , n , e^2 and τ will be constant and ρ will also be constant, ρ is independent of \vec{E} , the externally applied electric field.

11.6 Limitations of the Ohm's law:

Ohm's law is obeyed by various materials and devices. The devices for which potential difference (V) versus current (I) curve is a straight line passing through origin, inclined to V -axis, are called linear devices or ohmic devices (Fig. 11.4). Resistance of these devices is constant. Several conductors obey the Ohm's law. They follow the linear I - V characteristic.

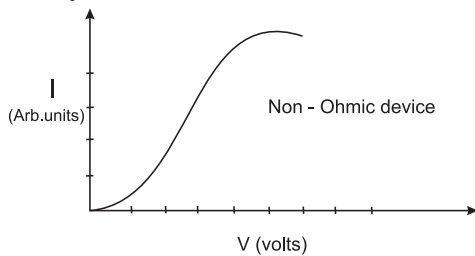

Fig. 11.5: I - V curve for non-Ohmic devices.

The devices for which the I - V curve is not a straight line as shown in Fig. 11.5 are called non-ohmic devices. They do not obey the Ohm's law and the resistance of these devices is a function of V or I ; e.g. liquid electrolytes,

vacuum tubes, junction diodes, thermistors etc. Resistance R for such non-linear devices at a particular value of the potential difference V is given by,

$$R = \lim_{\Delta I \rightarrow 0} \frac{\Delta V}{\Delta I} = \frac{dV}{dI} \quad \text{--- (11.16)}$$

where ΔV is the potential difference between the two values of potential

$$V - \frac{\Delta V}{2} \quad \text{to} \quad V + \frac{\Delta V}{2},$$

and ΔI is the corresponding change in the current.

11.7 Electrical Energy and Power:

Consider a resistor AB connected to a cell in a circuit shown in Fig. 11.6 with current flowing from A to B . The cell maintains a potential difference V between the two terminals of the resistor, higher potential at A and lower at B . Let Q be the charge flowing in time Δt through the resistor from A to B . The potential difference V between the two points A and B , is equal to the amount of work W , done to carry a unit positive charge from A to B . It is given by

$$V = \frac{W}{Q}, \quad W = VQ \quad \text{--- (11.17)}$$

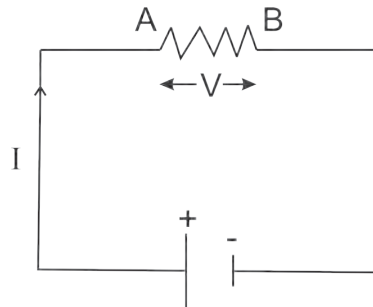

Fig. 11.6: A simple circuit with a cell and a resistor.

The cell provides this energy through the charge Q , to the resistor AB where the work is performed. When the charge Q flows from the higher potential point A to the lower potential point B , i.e. through a decrease in potential of value V , its potential energy decreases by an amount

$$\Delta U = QV = I \Delta t V \quad \text{--- (11.18)}$$

where I is current due to the charge Q flowing in time Δt . Where will this energy go? By the principle of conservation of energy, it is

converted into some other form of energy.

In the limit as $\Delta t \rightarrow 0$,

$$\frac{dU}{dt} = I.V \quad \text{--- (11.19)}$$

Here, $\frac{dU}{dt}$ is power, the time rate of transfer of energy and is given by,

$$P = \frac{dU}{dt} = I.V \quad \text{--- (11.20)}$$

We can also say that this power is transferred by the cell to the resistor or any other device in place of the resistor, such as a motor, a rechargeable battery etc.

Because of the presence of an electric field, the free electrons move across a resistor and there would be an increase in their kinetic energy as they move. When the electrons collide with the ion cores the energy gained by them is shared among the ion cores. Consequently, vibrations of the ions increase, resulting in heating up of the resistor. Thus, some amount of energy is dissipated in the form of heat in a resistor. The energy dissipated in time interval Δt is given by Eq. (11.18). The energy dissipated per unit time is actually the power dissipated and is given by Eq. (11.20).

Using Eq. (11.20), and using Ohm's law, $V=IR$,

$$\therefore P = \frac{V^2}{R} = I^2 R \quad \text{--- (11.21)}$$

It is the power dissipation across a resistor which is responsible for heating it up. For example, the filament of an electric bulb heats up to incandescence, radiating out heat and light.

Example 11.4 : An electric heater takes 6A current from a 230V supply line, calculate the power of the heater and electric energy consumed by it in 5 hours.

Solution : Given

$$I = 6A, V = 230V$$

We know that,

$$P = I \times V = (6A)(230V) = 1380 \text{ W}$$

$$P = 1.38 \text{ kW}$$

$$\text{Energy consumed} = \text{Power} \times \text{time}$$

$$= (1.38 \text{ kW}) \times (5 \text{ h})$$

$$= 6.90 \text{ kWh} \text{ (1.0 Kwh = 1 unit of power)}$$

$$= 6.9 \text{ units of electrical energy.}$$

11.8 Resistors:

Resistors are used to limit the current following through a particular path of a circuit. Commercially available resistors are mainly of two types :

Carbon resistors and Wire wound resistors. High value resistors are mostly carbon resistors. They are small and inexpensive. The values of these resistors are colour coded to mark their values in ohms. The colour coding is standardized by Electronic Industries Association (EIA). One such resistor is shown in Fig. 11.7.

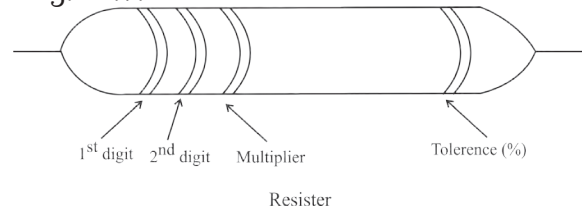

Fig. 11.7: Carbon composition resistor.

Colour code:

| Colours | 1st digit | 2nd digit | Multiplier | Tolerance |
|------------|-----------|-----------|------------------|------------|
| Black | 0 | 0 | $\times 10^0$ | |
| Brown | 1 | 1 | $\times 10^1$ | $\pm 1\%$ |
| Red | 2 | 2 | $\times 10^2$ | $\pm 2\%$ |
| Orange | 3 | 3 | $\times 10^3$ | |
| Yellow | 4 | 4 | $\times 10^4$ | |
| Green | 5 | 5 | $\times 10^5$ | |
| Blue | 6 | 6 | $\times 10^6$ | |
| Violet | 7 | 7 | $\times 10^7$ | |
| Gray | 8 | 8 | $\times 10^8$ | |
| White | 9 | 9 | $\times 10^9$ | |
| For Gold | | | $\times 10^{-1}$ | $\pm 5\%$ |
| For Silver | | | $\times 10^{-2}$ | $\pm 10\%$ |
| No colour | | | - | $\pm 20\%$ |

Easy Bytes:

Finding it difficult to memorize the colour code sequence? No need to worry, we have a one liner which will help you out "B. B. Roy in Great Britain has Very Good Wife"

B B R O Y G B V G W

This funny one liner makes it easy to recall the sequence of digits and multipliers.

In the four band resistor colour code illustrated in the above table, the first three bands (closest together) indicate the value in ohms. The first two bands indicate two numbers and third band often called decimal multiplier. The fourth band separated by a space from the three value bands, (so that you know which end to start reading from), indicates tolerance of the resistor.

Example

i. Colour code of resistor is

| | | | | |
|---------|--------|--------|--------|-----------|
| | Yellow | Violet | Orange | Gold |
| Value : | 4 | 7 | 10^3 | $\pm 5\%$ |

i.e. $47 \times 10^3 = 47000\Omega = 47k\Omega \pm 5\%$

The value of the resistor is $47k\Omega \pm 5\%$

ii. From given values of resistor; find the colour bands of this resistor

$$330\Omega = 33 \times 10^1$$

Orange Orange Brown tolerance band

11.8.1 Rheostat:

A rheostat shown in Fig. 11.8 is an adjustable resistor used in applications that require adjustment of current or resistance in an electric circuit. The rheostat can be used to adjust potential difference between two points in a circuit, change the intensity of lights and control the speed of motors, etc. Its resistive element can be a metal wire or a ribbon, carbon films or a conducting liquid, depending upon the application. In hi-fi equipment, rheostats are used for volume control.

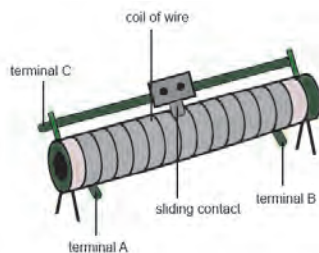

Fig . 11.8: Rheostat.

11.8.2 Combination of Resistors:

I. Series combination of Resistors:

In series combination of resistors, these are connected in single electrical path as shown in Fig 11.9. Hence the same electric current flows through each resistor in a series combination.

Because of series combination, the supply voltage between two resistors R_1 and R_2 is V_1 and V_2 , respectively and the same current I flows through the resistor R_1 and the resistor R_2 . i.e. in series combination, supply voltage is divided and the current remains the same in all the resistors.

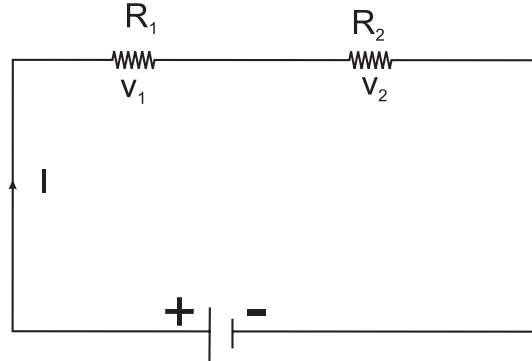

Fig. 11.9: Series combination of two resistors R_1 and R_2 .

According to Ohm's law,

$$R_1 = \frac{V_1}{I}, \quad R_2 = \frac{V_2}{I} \quad \text{--- (11.22)}$$

$$\text{Total voltage } V = V_1 + V_2 \quad \text{--- (11.23)}$$

From equation.... (11.22) and (11.23)

we write

$$V = I(R_1 + R_2) \quad \text{--- (11.24)}$$

$$\therefore V = I R_s \quad \text{--- (11.25)}$$

Thus the equivalent resistance of the series circuit $R_s = R_1 + R_2$

When a number of resistors are connected in series, the equivalent resistance is equal to the sum of individual resistances.

For n number of resistors,

$$R_s = R_1 + R_2 + R_2 + \dots + R_n = \sum_{i=1}^{i=n} R_i \quad \text{--- (11.26)}$$

II. Parallel Combination of Resistors:

In the parallel combination, the resistors are connected in such a way that the same voltage is applied across each resistor.

A number of resistors are said to be connected in parallel if all of them are connected between the same two electrical points each having individual path as shown in Fig. 11.10.

In parallel combination the total current I is divided into I_1 and I_2 as shown in the circuit

diagram Fig.11.10, whereas voltage V across them remains the same,

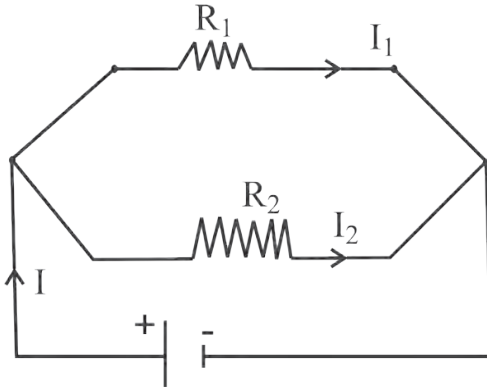

Fig. 11.10 : Two resistors in parallel combination.

$$I = I_1 + I_2 \quad \text{--- (11.27)}$$

where I_1 is current flowing through R_1 and I_2 is current flowing through R_2 .

When Ohm's law is applied to R_1

$$V = I_1 R_1 \quad \text{i.e. } I_1 = \frac{V}{R_1} \quad \text{--- (11.28a)}$$

Ohm's law applied to R_2

$$V = I_2 R_2 \quad \text{i.e. } I_2 = \frac{V}{R_2} \quad \text{--- (11.28b)}$$

From Eq. (11.27) and Eq. (11.28),

$$\therefore I = \frac{V}{R_1} + \frac{V}{R_2},$$

$$\text{If, } I = \frac{V}{R_p},$$

$$\frac{V}{R_p} = \frac{V}{R_1} + \frac{V}{R_2},$$

$$\therefore \frac{1}{R_p} = \frac{1}{R_1} + \frac{1}{R_2}, \quad \text{--- (11.29)}$$

where R_p is the equivalent resistance in parallel combination.

If n resistors $R_1, R_2, R_3, \dots, R_n$ are connected in parallel, the equivalent resistance of the combination is given by

$$\frac{1}{R_p} = \frac{1}{R_1} + \frac{1}{R_2} + \frac{1}{R_3} + \dots + \frac{1}{R_n} = \sum_{i=1}^n \frac{1}{R_i} \quad \text{--- (11.30)}$$

Thus when a number of resistors are connected in parallel, the reciprocal of the equivalent resistance is equal to the sum of the reciprocals of individual resistances.

Example 11.5: Calculate i) total resistance and ii) total current in the following circuit.

$$R_1 = 3\Omega, R_2 = 6\Omega, R_3 = 5\Omega, V = 14V$$

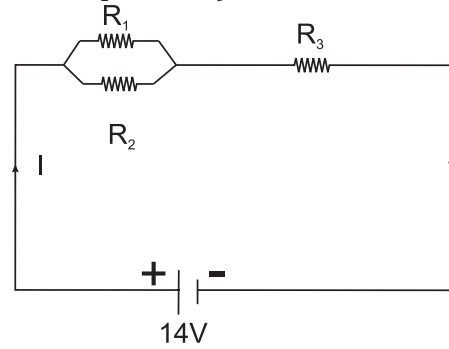

Circuit diagram

Solution:

i) Total resistance = $R_T = R_p + R_3$

$$R_p = \frac{R_1 R_2}{R_1 + R_2} = \frac{3 \times 6}{9} = 2\Omega$$

$$R_T = 2 + 5 = 7\Omega$$

$$\text{Total Resistance} = 7\Omega$$

ii) Total current :

$$I = \frac{V}{R_T} = \frac{14V}{7\Omega}$$

$$I = 2A$$

11.9 Specific Resistance (Resistivity):

At a particular temperature, the resistance of a given conductor is observed to depend on the nature of material of conductor, the area of its cross-section, and its length.

It is found that resistance R of a conductor of uniform cross section is

i. directly proportional to its length l ,

$$\text{i.e. } R \propto l$$

ii. inversely proportional to its area of cross section A ,

$$\text{i.e. } R \propto \frac{l}{A}$$

From **i** and **ii**

$$R = \rho \frac{l}{A} \quad \text{--- (11.31)}$$

where ρ is a constant of proportionality and it is called specific resistance or resistivity of the material of the conductor at a given temperature.

From Eq. (11.31), we write

$$\rho = \frac{RA}{l} \quad \text{--- (11.32)}$$

SI unit of resistivity is ohm-meter. Resistivity of a conductor is numerically the resistance per unit length, and per unit area of cross-section of material of the conductor.

i.e. when, $R = 1\Omega$, $A = 1\text{m}^2$ and $l = 1\text{m}$,

then, $\rho = 1\Omega\text{m}$

Conductivity : Reciprocal of resistivity is called conductivity of a material, $\sigma = (\rho)^{-1}$.

SI unit of σ is: $(\Omega\text{m})^{-1}$ i.e. siemens/meter (Sm^{-1})

Table 11.1 : Resistivity of various materials

| Material | Resistivity ρ ($\Omega\cdot\text{m}$) | Material | Resistivity ρ ($\Omega\cdot\text{m}$) |
|-------------------|---|-----------------------|---|
| Conductors | | Semiconductors | |
| Silver | 1.59×10^{-8} | Carbon | 3.5×10^{-5} |
| Copper | 1.72×10^{-8} | Germanium | 0.5 |
| Gold | 2.44×10^{-8} | Silicon | 3×10^4 |
| Aluminium | 2.82×10^{-8} | Insulators | |
| Tungsten | 5.6×10^{-8} | Glass | $10^{11}\text{-}10^{13}$ |
| Iron | 9.7×10^{-8} | Mica | $10^{11}\text{-}10^{15}$ |
| Mercury | 95.8×10^{-8} | Rubber (hard) | $10^{13}\text{-}10^{16}$ |
| Nichrome (alloy) | 100×10^{-8} | Teflon | 10^{16} |
| | | Wood (maple) | 3×10^8 |

Example 11.6: Calculate the resistance per metre, at room temperature, of a constantan (alloy) wire of diameter 1.25mm. The resistivity of constantan at room temperature is $5.0 \times 10^{-7} \Omega\text{m}$.

Solution: $\rho = 5.0 \times 10^{-7} \Omega\text{m}$

$$d = 1.25 \times 10^{-3} \text{ m}$$

$$r = .625 \times 10^{-3} \text{ m}$$

$$\text{Cross-sectional Area} = \pi r^2$$

$$\text{Resistivity } \rho = \frac{RA}{l}$$

$$\text{Resistance per meter} = \frac{R}{l}$$

$$\text{i.e. } \frac{R}{l} = \frac{\rho}{A} = \frac{5 \times 10^{-7}}{(0.625 \times 10^{-3})^2 \times 3.142}$$

$$\frac{R}{l} = 0.41 \Omega\text{m}^{-1}$$

\therefore Resistance per metre = $0.41 \Omega\text{m}^{-1}$

Resistivity ρ is a property of a material, while the resistance R refers to a particular object. Similarly, the electric field \vec{E} at a point is specified in a material with the potential difference across the resistance, and the current density \vec{J} in a material instead of the current I in the resistor. Then for an isotropic material,

$$\rho = \frac{E}{J} \quad \text{or} \quad \vec{E} = \rho \vec{J} \quad \text{---- (11.33)}$$

Again, the SI unit of ρ is

$$\frac{\text{unit}(E)}{\text{unit}(J)} = \frac{\text{V/m}}{\text{A/m}^2} = \frac{\text{V}}{\text{A}} \text{m} = \Omega\cdot\text{m}$$

In terms of conductivity σ of a material, from (11.33),

$$\vec{J} = \frac{1}{\rho} \vec{E} = \sigma \vec{E} \quad \text{--- (11.34)}$$

For a particular resistor, we had (Eq. 11.9) the resistance R given by

$$R = \frac{V}{I}$$

Compare this with the above Eq (11.33).

11.10 Variation of Resistance with Temperature:

Resistivity of a material varies with temperature. It is a property of material. Fig. 11.11 shows the variation of resistivity of copper as a function of temperature (K). It can be seen that the variation is linear over a certain range of temperatures. Such a linear relation can be expressed as,

$$\rho = \rho_0 [1 + \alpha(T - T_0)], \quad \text{--- (11.35)}$$

where T_0 is the chosen reference temperature and ρ_0 in the resistivity at the chosen temperature, for example, T_0 can be 0°C .

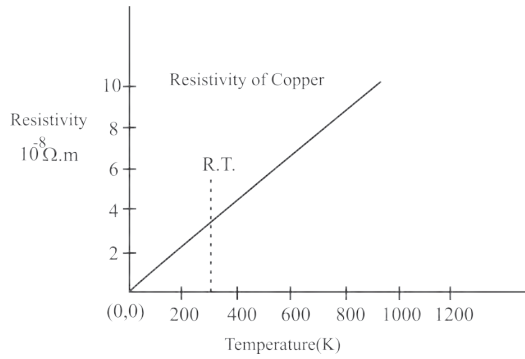

Fig. 11.11: Resistivity as a function of temperature (K).

In the above Eq. (11.35),

$$\alpha = \frac{\rho - \rho_0}{\rho_0(T - T_0)} = \frac{R - R_0}{R_0(T - T_0)} \quad \text{--- (11.36)}$$

Here, α is called the temperature coefficient of resistivity. Table (11.1) shows the resistivity of some of the metals. The temperature coefficient of resistance is defined as the increase in resistance per unit original resistance at the chosen reference temperature, per degree rise in temperature. The unit of α is $^{\circ}\text{C}^{-1}$ or $^{\circ}\text{K}^{-1}$ (per degree celcius or per degree kelvin).

From Eq. (11.36)

$$R = R_0 [1 + \alpha (T - T_0)] \quad \text{--- (11.37)}$$

For small difference in temperatures,

$$\alpha = \frac{1}{R_0} \cdot \frac{dR}{dT} \quad \text{--- (11.38)}$$



Do you know ?

Here, the temperature difference is more important than the temperature alone. Therefore, as the sizes of degrees on the Celsius scale and the Absolute scale are identical, any scale can be used.

Example 11.7: A piece of platinum wire has resistance of 2.5Ω at 0°C . If its temperature coefficient of resistance is $4 \times 10^{-3}/^{\circ}\text{C}$. Find the resistance of the wire at 80°C .

Solution:

$$R_0 = 2.5 \Omega$$

$$\alpha = 0.004/^{\circ}\text{C}$$

$$T - 0 = T = 80^{\circ}\text{C}$$

$$R_T = R_0(1 + \alpha T)$$

$$R_T = 2.5 (1 + 0.004 \times 80) = 2.5 (1 + 0.32)$$

$$R_T = 2.5 \times 1.32$$

$$R_T = 3.3 \Omega$$

Superconductivity :

We know that the resistivity of a metal decreases as the temperature decreases. In case of some metals and metal alloys, the resistivity suddenly drops to zero at a particular temperature (T_c). This temperature is called critical temperature, for example, mercury loses its resistance completely to zero at 4.2K .

Superconductivity can be harnessed so as to be useful for mankind. It is already in use in obtaining very high magnetic field (a few Tesla) in superconducting magnet. These magnets are used in research quality NMR spectrometers. For its operation, the current carrying coils are required to be kept at a temperature less than the critical temperature of the coil material.

11.11 Electromotive Force (emf):

When charges flow through a conductor, a potential difference has to be established between the two ends of the conductor. For a steady flow of charges, this potential difference is required to be maintained across the two ends of the conductor, the terminals. There is a device that does so by doing work on the charges, thereby maintaining the potential difference. Such a device is called an emf device and it provides the emf ϵ . The charges move in the conductor owing to the energy provided by the emf device. The device supplies this energy through the work it does.

You must have used some of these emf devices. Power cells, batteries, Solar cells, fuel cells, and even generators, are some examples of emf devices familiar to you.

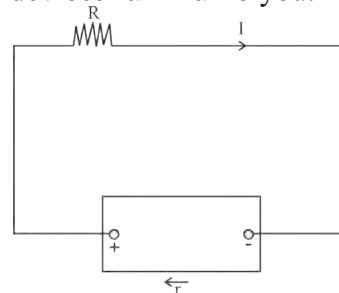

Fig. 11.12: Circuit with emf device.

Fig. 11.12 shows a circuit with an emf device and a resistor R . Here, the emf device keeps the positive terminal (+) at a higher electric potential than the negative terminal (-).

The emf is represented by an arrow from the negative terminal to the positive terminal of a device such as a Voltaic cell. When the circuit is open, there is no net flow of charge carriers within the device. When connected in a circuit, there is a flow of carriers from one terminal to the other terminal inside the emf device. The positive charge carriers move towards the positive terminal which acts as cathode inside the emf device. Thus the positive charge carriers move from the region of lower potential energy, to the region of higher potential energy which is cathode inside the emf device. Here, the energy source is chemical in nature. In a Solar cell, it is the photon energy in the Solar radiation.

Now suppose that a charge dq flows through the cross section of the circuit (Fig. 11.12), in time dt .

It is clear that the same amount of charge dq flows throughout the circuit, including the emf device. It enters the negative terminal (low potential terminal) and leaves the positive terminal (higher potential terminal). Hence, the device must do work dw on the charge dq , so that it moves in the above manner. Thus we define the emf of the emf device.

$$\varepsilon = \frac{dw}{dq} \quad \text{--- (11.39)}$$

The SI unit of emf is joule/coulomb (J/C).

In an ideal device, there is no internal resistance to the motion of charge carriers. The emf of the device is then equal to the potential difference across the two terminals of the device. In a real emf device, there is an internal resistance to the motion of charge carriers. If such a device is not connected in a circuit, there is no current through it. In that case the emf is equal to the potential difference across the two terminals of the emf device connected in a circuit, there is no current through it. If a current (I) flows through an emf device, there is an internal resistance (r) and the emf (ε) differs

from the potential difference across its two terminals (V).

$$V = \varepsilon - (I)(r) \quad \text{--- (11.40)}$$

The negative sign is due to the fact that the current I flows through the emf device from the negative terminal to the positive terminal.

By the application of Ohm's law Eq. (11.9),

$$V = IR$$

$$\text{Hence } IR = \varepsilon - Ir \quad \text{--- (11.41)}$$

Or

$$I = \frac{\varepsilon}{R + r} \quad \text{--- (11.42)}$$

Thus, the maximum current that can be drawn from the emf device is when $R = 0$, i.e.

$$I_{max} = \frac{\varepsilon}{r} \quad \text{--- (11.43)}$$

This is the maximum allowed current from an emf device (or a cell). This decides the maximum current rating of a cell or a battery.

11.12 Cells in Series:

In a series combination, cells are connected in single electrical path, such that the positive terminal of one cell is connected to the negative terminal of the next cell, and so on. The terminal voltage of battery/cell is equal to the sum of voltages of individual cells in series, as shown in Fig 11.13 a.

Figure shows two 1.5V cells in series. This combination provides total voltage of 3.0V (1.5×2).

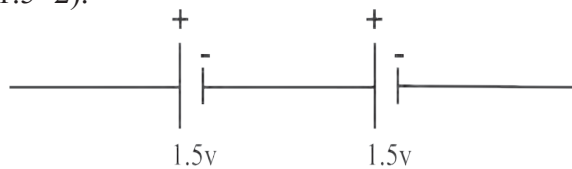

Fig. 11.13 (a): Cells in parallel.

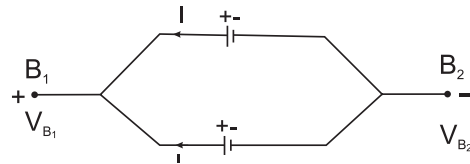

Fig. 11.13 (b): Cells in parallel.

The equivalent emf of n number of cells in series combination is the algebraic sum of their individual emf. The equivalent internal resistance of n cells in a series combination is the sum of their individual internal resistance.

$$V = \sum_i \varepsilon_i - I \cdot \sum_i r_i \quad \text{--- (11.44)}$$

• **Advantages of cells in series.**

- (i) The cells connected in series produce a larger resultant voltage.
- (ii) Cells which are damaged can be easily identified, hence can be easily replaced.

11.13 Cells in parallel:

Consider two cells which are connected in parallel. Here, positive terminals of all the cells are connected together and the negative terminals of all the cells are connected together. In parallel connection, the current is divided among the branches i.e. I_1 and I_2 as shown in Fig. 11.13b. Consider points B_1 and B_2 having potentials V_{B_1} and V_{B_2} , respectively.

For the first cell the potential difference across its terminals is,

$$V = V_{B_1} - V_{B_2} = \varepsilon_1 - I_1 r_1 \quad \text{--- (11.45)}$$

$$\therefore I_1 = \frac{\varepsilon_1 - V}{r_1} \quad \text{--- (11.46)}$$

Point B_1 and B_2 are connected exactly similarly to the second cell.

Hence, considering the second cell we write,

$$V = V_{B_1} - V_{B_2} = \varepsilon_2 - I_2 r_2; I_2 = \frac{\varepsilon_2 - V}{r_2} \quad \text{--- (11.47)}$$

We know that $I = I_1 + I_2$

Combining the last three equations,

$$\therefore I = \frac{\varepsilon_1}{r_1} - \frac{V}{r_1} + \frac{\varepsilon_2}{r_2} - \frac{V}{r_2} \quad \text{--- (11.48)}$$

$$= \left(\frac{\varepsilon_1}{r_1} + \frac{\varepsilon_2}{r_2} \right) - V \left(\frac{1}{r_1} + \frac{1}{r_2} \right)$$

$$\text{Thus, } V \left(\frac{1}{r_1} + \frac{1}{r_2} \right) = \left(\frac{\varepsilon_1}{r_1} + \frac{\varepsilon_2}{r_2} \right) - I$$

$$\therefore V \left(\frac{r_1 + r_2}{r_1 r_2} \right) = \frac{\varepsilon_1 r_2 + \varepsilon_2 r_1}{r_1 r_2} - I$$

$$V = \frac{\varepsilon_1 r_2 + \varepsilon_2 r_1}{r_1 + r_2} - I \frac{r_1 r_2}{r_1 + r_2} \quad \text{--- (11.49)}$$

If we replace the cells by a single cell connected between points B_1 and B_2 with the emf ε_{eq} and the internal resistance r_{eq} as in Fig. (11.13b),

then,

$$V = \varepsilon_{eq} - I r_{eq} \quad \text{--- (11.50)}$$

Considering Eq. (11.49) and Eq. (11.50) we can write,

$$\varepsilon_{eq} = \frac{\varepsilon_1 r_2 + \varepsilon_2 r_1}{r_1 + r_2}$$

$$r_{eq} = \frac{r_1 r_2}{r_1 + r_2}$$

$$\text{i.e. } \frac{1}{r_{eq}} = \frac{1}{r_1} + \frac{1}{r_2}$$

$$\frac{\varepsilon_{eq}}{r_{eq}} = \frac{\varepsilon_1}{r_1} + \frac{\varepsilon_2}{r_2} \quad \text{--- (11.51)}$$

For n number of cells connected in parallel with emf $\varepsilon_1, \varepsilon_2, \varepsilon_3, \dots, \varepsilon_n$ and internal resistance $r_1, r_2, r_3, \dots, r_n$

$$\frac{1}{r_{eq}} = \frac{1}{r_1} + \frac{1}{r_2} + \frac{1}{r_3} + \dots + \frac{1}{r_n} \quad \text{--- (11.52)}$$

$$\text{and } \frac{\varepsilon_{eq}}{r_{eq}} = \frac{\varepsilon_1}{r_1} + \frac{\varepsilon_2}{r_2} + \dots + \frac{\varepsilon_n}{r_n}$$

$$\text{--- (11.53)}$$

Substitution of emfs should be done algebraically by considering proper \pm signs according to polarity.

- **Advantages of cells in parallel :** For cells connected in parallel in a circuit, the circuit will not break open even if a cell gets damaged or open.
- **Disadvantages of cells in parallel :** The voltage developed by the cells in parallel connection cannot be increased by increasing number of cells present in circuit.

11.14 Types of Cells:

Electrical cells can be divided into several categories like primary cell, secondary cell, fuel cell, etc.

A primary cell cannot be charged again. It can be used only once. Dry cells, alkaline cells are different examples of primary cells. Primary cells are low cost and can be used easily. But these are not suitable for heavy loads. Secondary cells are used for such applications. The secondary cell are rechargeable and can be reused. The chemical reaction in a secondary cells is reversible. Lead acid cell, and fuel cell

are some examples of secondary cells. Lead acid battery is used widely in vehicles and other applications which require high load currents. Solar cells are secondary cells that convert Solar energy into electrical energy.

Fuel cells vehicles (FCVs) are electric vehicles that use fuel cells instead of lead acid batteries to power the vehicles. Hydrogen is used as a fuel in fuel cells. The by-product after its burning is water. This is important in terms of reducing emission of greenhouse gases produced by traditional gasoline fueled vehicles. The hydrogen fuel cell vehicles are thus more environment friendly.

Example 11.8: A network of resistors is connected to a 15 V battery with internal resistance 1 Ω as shown in the circuit diagram.

Calculate

- The equivalent resistance,
- Current in each resistor,
- Voltage drops V_{AB} , V_{BC} and V_{DC} .

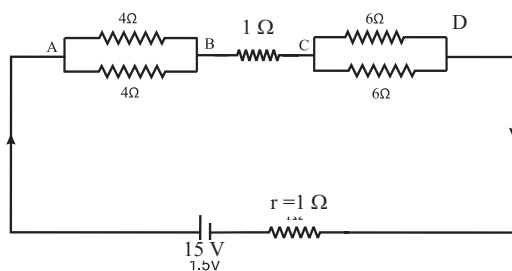

Solution :

i) Equivalent Resistance (R_{eq}) = $R_{AB} + R_{BC} + R_{DC}$

$$R_{AB} = \frac{4 \times 4}{4 + 4} = 2\Omega, \quad R_{CD} = \frac{6 \times 6}{6 + 6} = 3\Omega$$

$$R_{BC} = 1\Omega$$

$$R_T = R_{eq} = 2 + 1 + 3 = 6\Omega$$

∴ Equivalent Resistance is 6 Ω

ii. Current in each resistor :

Total current I in the circuit is,

$$I = \frac{\epsilon}{R_T + r} = \frac{15}{6 + 1} = 2.1A$$

Consider resistors between A and B.

Let I_1 be the current through one of the 4Ω resistors and I_2 be the current in the other resistor

$$I_1 \times 4 = I_2 \times 4$$

that is, $I_1 = I_2$ from symmetry of the two arms.

$$\text{But } I_1 + I_2 = I = 2.1A$$

$$\therefore I_1 = I_2 = 1.05A$$

that is, the current in each 4Ω resistor is 1.05A, the current in 1Ω resistor between B and C would be 2.1A.

Now, consider the resistances between C and D

Let I_3 be the current through one of the 6 Ω resistors and I_4 be the current in the other resistor.

$$I_3 \times 6 = I_4 \times 6$$

$$\therefore I_3 = I_4 = 1.05A$$

That is, current in each 6 Ω resistor is 1.05A

iii. Voltage drop across BC is V_{BC}

$$V_{BC} = I \times 1 = 2.1 \times 2.1 = 2V$$

Voltage drop across CD is V_{CD}

$$V_{CD} = I \times R_{CD} = 2.1 \times 3 = 6.3V$$

[Note : Total voltage drop across AD is (4.2 V + 2.1V + 6.3 V) = 12.6 V, while its emf is 15 V. The loss of the voltage is 2.4 V].



Internet my friend

<https://www.britannica.com/science/superconductivityphysics>



Exercises

1. Choose correct alternative

- i) You are given four bulbs of 25 W, 40 W, 60 W and 100 W of power, all operating at 230 V. Which of them has the lowest resistance?
 (A) 25 W (C) 40 W
 (B) 60 W (D) 100 W
- ii) Which of the following is an ohmic conductor?
 (A) transistor (B) vacuum tube
 (C) electrolyte (D) nichrome wire
- iii) A rheostat is used
 (A) to bring on a known change of resistance in the circuit to alter the current
 (B) to continuously change the resistance in any arbitrary manner and thereby alter the current
 (C) to make and break the circuit at any instant
 (D) neither to alter the resistance nor the current
- iv) The wire of length L and resistance R is stretched so that its radius of cross-section is halved. What is its new resistance?
 (A) $5R$ (B) $8R$
 (C) $4R$ (D) $16R$
- v) Masses of three pieces of wires made of the same metal are in the ratio 1:3:5 and their lengths are in the ratio 5:3:1. The ratios of their resistances are
 (A) 1:3:5 (B) 5:3:1
 (C) 1:15:125 (D) 125:15:1
- vi) The internal resistance of a cell of emf 2V is 0.1Ω it is connected to a resistance of 0.9Ω . The voltage across the cell will be
 (A) 0.5 V (B) 1.8 V
 (C) 1.95 V (D) 3V
- vii) 100 cells each of emf 5V and internal resistance 1Ω are to be arranged so as to produce maximum current in a 25Ω resistance. Each row contains equal

number of cells. The number of rows should be

- (A) 2 (B) 4
 (C) 5 (D) 100

- viii) Five dry cells each of voltage 1.5 V are connected as shown in diagram

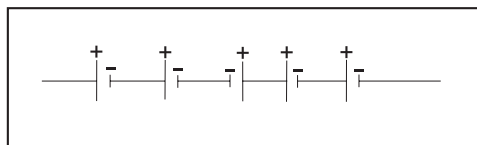

What is the overall voltage with this arrangement?

- (A) 0V (B) 4.5V
 (C) 6.0V (D) 7.5V

2. Give reasons / short answers

- i) In given circuit diagram two resistors are connected to a 5V supply.

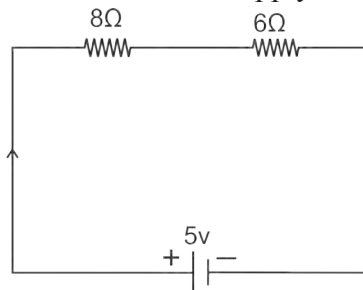

a] Calculate potential difference across the 8Ω resistor.

b] A third resistor is now connected in parallel with 6Ω resistor. Will the potential difference across the 8Ω resistor be larger, smaller or the same as before? Explain the reason for your answer.

- ii) Prove that the current density of a metallic conductor is directly proportional to the drift speed of electrons.

3. Answer the following questions.

- i) Distinguish between Ohmic and non-ohmic substances; explain with the help of example.
- ii) DC current flows in a metal piece of non-uniform cross-section. Which of these quantities remains constant along the conductor: current, current density or drift speed?

4. Solve the following problems.

- i) What is the resistance of one of the rails of a railway track 20 km long at 20° C? The cross section area of rail is 25 cm² and the rail is made of steel having resistivity at 20° C as $6 \times 10^{-8} \Omega \text{ m}$.
[Ans: 0.48 Ω]
- ii) A battery after a long use has an emf 24 V and an internal resistance 380 Ω . Calculate the maximum current drawn from the battery? Can this battery drive starting motor of car?
[Ans: 0.063 A]
- iii) A battery of emf 12 V and internal resistance 3 Ω is connected to a resistor. If the current in the circuit is 0.5 A,
a] Calculate resistance of resistor.
b] Calculate terminal voltage of the battery when the circuit is closed.
[Ans: a) 21 Ω , b) 10.5 V]
- iv) The magnitude of current density in a copper wire is 500 A/cm². If the number of free electrons per cm³ of copper is 8.47×10^{22} calculate the drift velocity of the electrons through the copper wire (charge on an e = $1.6 \times 10^{-19} \text{ C}$)
[Ans: $3.69 \times 10^{-4} \text{ m/s}$]
- v) Three resistors 10 Ω , 20 Ω and 30 Ω are connected in series combination.
i] Find equivalent resistance of series combination.
ii] When this series combination is connected to 12V supply, by neglecting the value of internal resistance, obtain potential difference across each resistor.
[Ans: i) 60 Ω , ii) 2 V, 4 V, 6 V]
- vi) Two resistors 1k Ω and 2k Ω are connected in parallel combination.
i] Find equivalent resistance of parallel combination
ii] When this parallel combination is connected to 9 V supply, by neglecting internal resistance calculate current through each resistor.
[Ans: i) 0.66 k Ω , ii) 9 mA, 4.5 mA]
- vii) A silver wire has a resistance of 4.2 Ω at 27° C and resistance 5.4 Ω at 100° C. Determine the temperature coefficient of resistance.
[Ans: $3.91 \times 10^{-3}/^\circ\text{C}$]
- viii) A 6m long wire has diameter 0.5 mm. Its resistance is 50 Ω . Find the resistivity and conductivity.
[Ans: $1.636 \times 10^{-6} \Omega/\text{m}$, $6.112 \times 10^5 \text{ m}/\Omega$]
- ix) Find the value of resistances for the following colour code.
1. Blue Green Red Gold
[Ans: 6.5 k $\Omega \pm 5\%$]
2. Brown Black Red Silver
[Ans: 1.0 k $\Omega \pm 10\%$]
3. Red Red Orange Gold
[Ans: 2.2 k $\Omega \pm 5\%$]
4. Orange White Red Gold
[Ans: 3.9 k $\Omega \pm 5\%$]
5. Yellow Violet Brown Silver
[Ans: 4.70 k $\Omega \pm 10\%$]
- x) Find the colour code for the following value of resistor having tolerance $\pm 10\%$
a) 330 Ω b) 100 Ω c) 47k Ω
d) 160 Ω e) 1k Ω
- xi) A current 4A flows through an automobile headlight. How many electrons flow through the headlight in a time 2hrs.
[Ans : 1.8×10^{23}]
- xii) The heating element connected to 230V draws a current of 5A. Determine the amount of heat dissipated in 1 hour (J = 4.2 J/cal.).
[Ans : 985.7 kcal]
