



Let's Study

- Directed angle.
- Angles of different measurements
- Units of measure of an angle
- Length of an arc of a circle.
- Area of a sector of a circle.



Let's Recall

- We know how to draw the acute angles of different measures.
- In a circle we can find arc length and area of a sector in terms of the central angle and the radius.

Activity No. 1

Draw the angle ABC of measure 40°

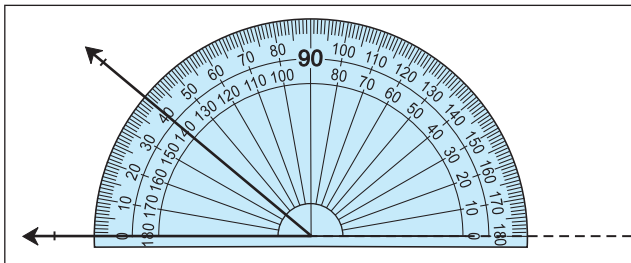

Fig. 1.1

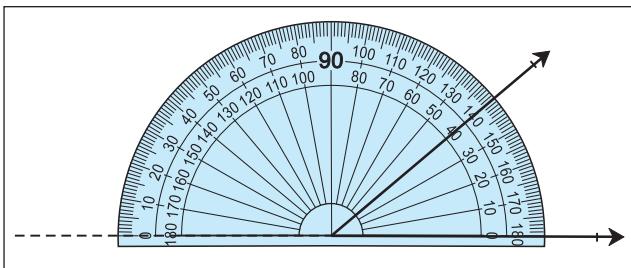

Fig. 1.2

In the Figs 1.1 and 1.2 both the angles are of 40° . But one is measured in anticlockwise direction and the other is measured in clockwise direction.

Now we will differentiate between such angles.



Let's Learn

1.1 Directed Angles:

Consider the ray OA. Rotate it about O till it takes the position OB as shown in Fig. 1.3. Then angle so obtained due to the rotation is called directed angle AOB. We define the notion of directed angle as follows:

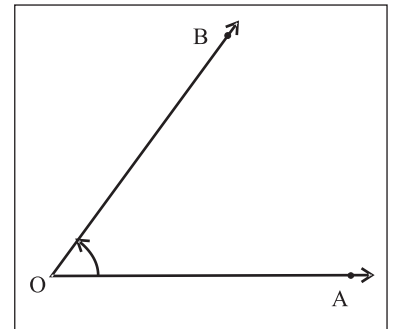

Fig. 1.3

Definition:

The ordered pair of rays (\vec{OA}, \vec{OB}) together with the rotation of the ray OA to the position of the ray OB is called the **directed angle** $\sphericalangle AOB$.

If the rotation of the initial ray is anticlockwise then the measure of directed angle is considered as **positive** and if it is clockwise then the measure of directed angle is considered as **negative**. In the ordered pair (\vec{OA}, \vec{OB}) , the ray OA is called the **initial arm** and the ray OB is called the **terminal arm**.

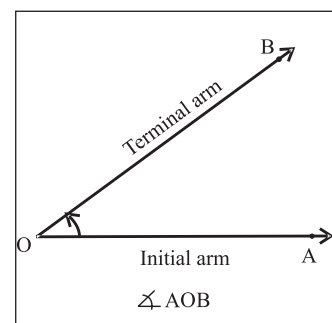

Fig. 1.3(a)

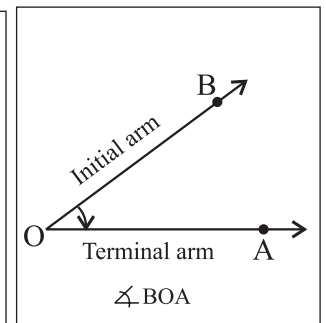

Fig. 1.3(b)

O is called the vertex as shown in fig 1.3(a) and 1.3(b).

Observe Fig 1.3(b) and note that

$$(\vec{OA}, \vec{OB}) \neq (\vec{OB}, \vec{OA})$$

$$\sphericalangle AOB \neq \sphericalangle BOA$$

$\sphericalangle AOB \neq \sphericalangle BOA$ even though they have same amount of rotation.

Zero angle:

If the ray OA has zero rotation, that is it does not rotate, the initial arm itself is a terminal arm OB, the angle so formed is zero angle.

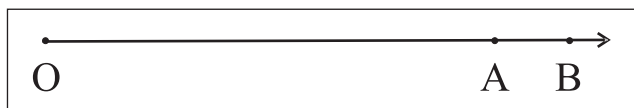

Fig. 1.4

One rotation angle:

After one complete rotation if the initial ray OA coincides with the terminal ray OB then so formed angle is known as one rotation angle $m\sphericalangle AOB = 360^\circ$.

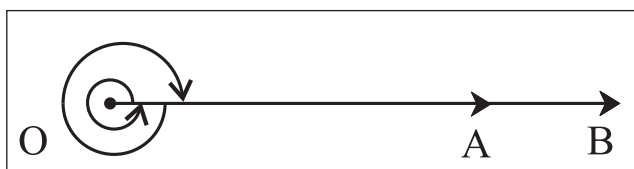

Fig. 1.5

Straight angle:

After the rotation, if the initial ray OA and the terminal ray OB are in opposite directions then directed angle so formed is known as straight angle (fig. 1.6).

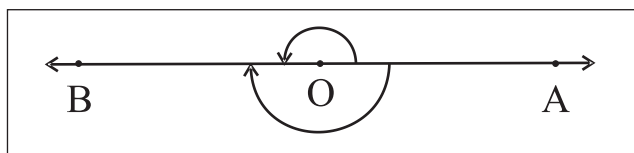

Fig. 1.6

Note that in this case AOB is a straight line.

and, half of one rotation angle is straight angle.

Right angle:

One fourth of one rotation angle is called as one right angle, it is also half of a straight angle. One rotation angle is four right angles.

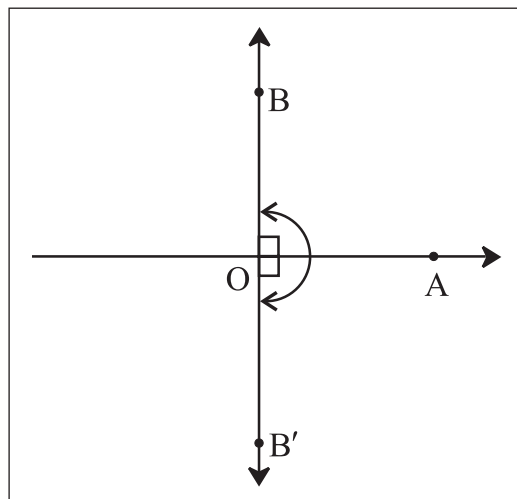

Fig. 1.7

Angles in Standard position :

In the rectangular co-ordinate system, a directed angle with its vertex at origin O and the initial ray along the positive X-axis, is called angle in standard position.

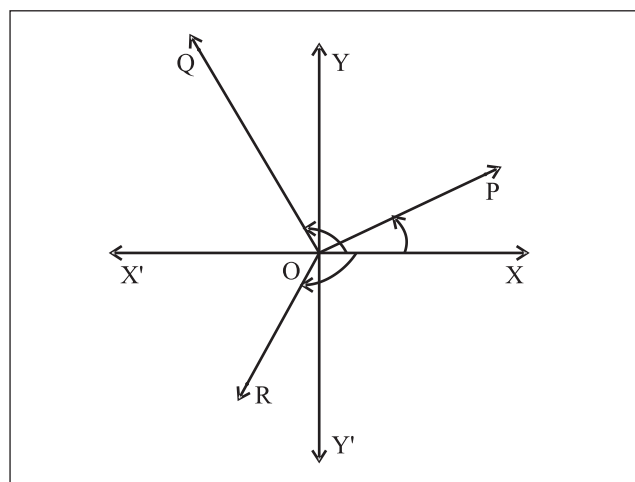

Fig. 1.8

In adjacent Fig. 1.8, $\sphericalangle XOP$, $\sphericalangle XOQ$ and $\sphericalangle XOR$ are in standard positions. But, $\sphericalangle POQ$ is not in standard position.

Angle in a Quadrant:

A directed angle in standard position is said to be in a particular quadrant if its terminal ray lies in that quadrant.

In Fig. 1.8, directed angles $\sphericalangle XOP$, $\sphericalangle XOQ$ and $\sphericalangle XOR$ lie in first, second and third quadrants respectively.

Quadrantal Angles:

A directed angle in standard position whose terminal ray lies along X-axis or Y-axis is called a **quadrantal angle**.

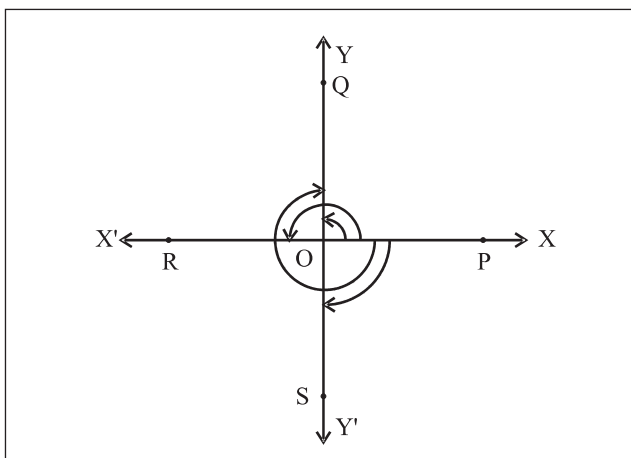

Fig. 1.9

In Fig. 1.9, $\sphericalangle XOP$, $\sphericalangle XOQ$, $\sphericalangle XOR$ and $\sphericalangle XOS$ are all quadrantal angles.

Co-terminal angles:

Directed angles of different amount of rotation having the same positions of, initial rays and terminal rays are called **co-terminal angles**.

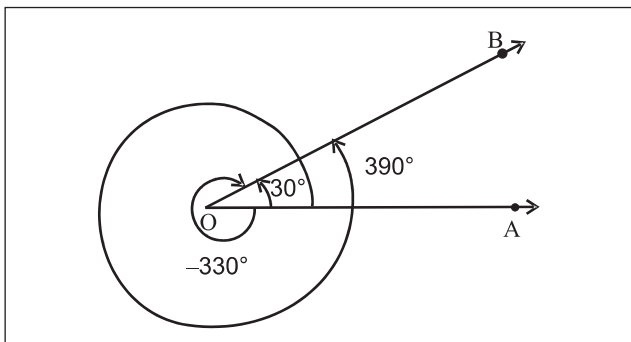

Fig. 1.10 (a)

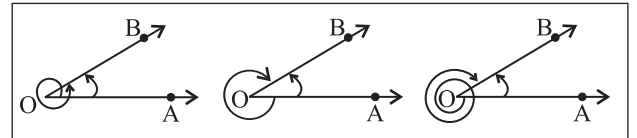

Fig. 1.10 (b)

In Fig. 1.10(a), the directed angles having measure 30° , 390° , -330° have the same initial arm, ray \vec{OA} and the same terminal arm, ray \vec{OB} . Hence, these angles are co-terminal angles.

If the two directed angles are co-terminal angles then difference between measures of these two directed angles is an integral multiple of 360° e.g. in figure 1.10(a), $390^\circ - (-330^\circ) = 720^\circ = 2 \times 360^\circ$.

1.1.1 Measures of angles:

The amount of rotation from the initial ray OA to the terminal ray OB gives the measure of angle AOB. It is measured in two systems.

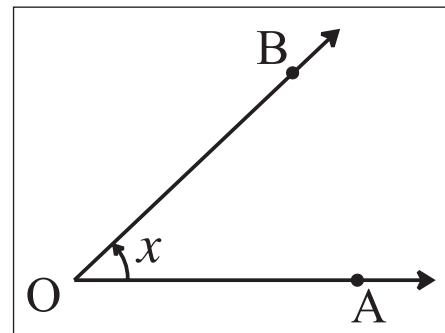

Fig. 1.11

- 1) Sexagesimal system (Degree measure)
- 2) Circular system (Radian measure)

1.1.2 Sexagesimal System (Degree Measure):

In this system, the unit of measurement of angle is a degree.

One rotation angle is divided into 360 equal parts, the measure of each part is called as one degree angle.

$$\therefore \left(\frac{1}{360}\right)^{\text{th}} \text{ part of one complete rotation}$$

is called **one degree** and is denoted by 1° .

$\left(\frac{1}{60}\right)^{\text{th}}$ part of one degree is called one minute and is denoted by 1'.

$\left(\frac{1}{60}\right)^{\text{th}}$ part of one minute is called one second and is denoted by 1''.

$1^\circ = 60'$ $1' = 60''$

m \sphericalangle (one rotation angle) = 360°

m \sphericalangle (straight angle) = 180°

m \sphericalangle (right angle) = 90°

1.1.3 Circular System (Radian Measure):

In this system, the unit of measurement of an angle is a radian.

Let r be the radius of a circle with centre O . Let A and B be two points on circle such that the length of arc AB is r . Then the measure of the central angle AOB is defined as 1 radian. It is denoted by 1^c .

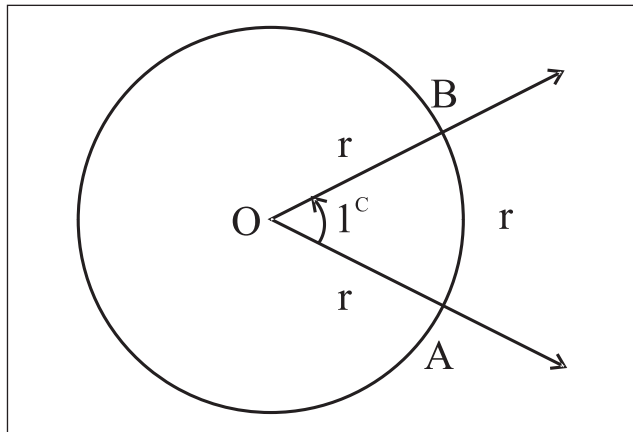

Fig. 1.12

Thus, one radian is the measure of an angle subtended at the centre of a circle by an arc whose length is equal to the radius of the circle.

Theorem :

The radian so defined is independent of the radius of the circle used and $\pi^c = 180^\circ$.

Proof: Let us consider a circle with centre at O and radius r . Let AB be an arc of length r . Join OA and OB . Then $\angle AOB = 1^c$. Produce AO to meet the circle at C .

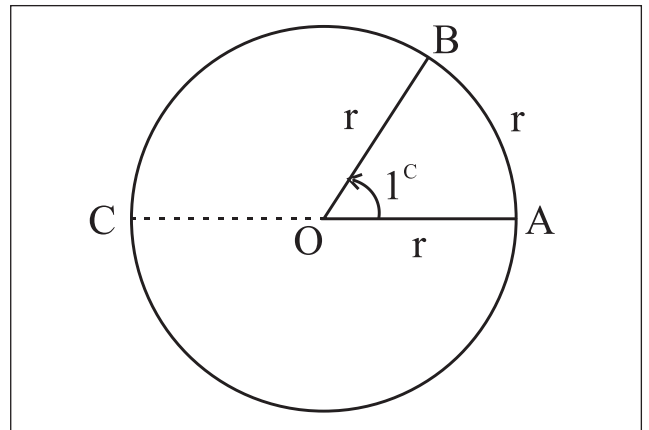

Fig. 1.13

Clearly, $\angle AOC =$ a straight angle
 $= 2$ right angles

Since measures of the angles at the centre of a circle are proportional to the lengths of the corresponding arcs subtending them:

$$\begin{aligned} \therefore \frac{m\angle AOB}{m\angle AOC} &= \frac{l(\text{arc } AB)}{l(\text{arc } ABC)} \\ &= \frac{r}{\frac{1}{2}(2\pi r)} = \frac{1}{\pi} \end{aligned}$$

$$\therefore m\angle AOB = \frac{1}{\pi} \cdot m\angle AOC$$

$$\therefore 1^c = m\angle AOB = \frac{(2 \text{ right angles})}{\pi},$$

a constant independent of r .

Hence one radian is well defined.

Also, $\pi^c = 2$ right angles = 180° .

Hence, a radian is a constant angle and two right angles = $180^\circ = \pi^c$

Activity 2 : Verify the above result by taking the circles having different radii.

Let an angle have its measure r in radian and θ in degrees. Then its proportion with the straight angle is the same in either measure.

$$\therefore \frac{r}{\pi} = \frac{\theta}{180} \quad \therefore r^c = \theta^\circ \times \frac{\pi}{180}$$

We use this relation to convert radian measure into degree and vice-versa.

Notes:

- i) To convert degree measure into radian measure, multiply degree measure by $\frac{\pi}{180}$.
- ii) To convert radian measure into degree measure, multiply radian measure by $\frac{180}{\pi}$.
- iii) Taking $\pi = 3.14$,

$$\begin{aligned} \text{we have } 1^\circ &= \left(\frac{180}{\pi}\right)^\circ \\ &= 57.3248^\circ \end{aligned}$$

Here fractional degree is given in decimal fraction. It can be converted into minutes and seconds as follows

$$\begin{aligned} 0.3248^\circ &= (0.3248 \times 60)' \\ &= 19.488' \\ &= 19' + (.488 \times 60)'' \\ &\approx 19' 29'' \end{aligned}$$

Thus, $1^\circ = 57^\circ 19' 29''$

- iv) In the table given below, certain degree measures are expressed in terms of radians.

Degree	15	30	45	60	90	120	180	270	360
Radian	$\frac{\pi}{12}$	$\frac{\pi}{6}$	$\frac{\pi}{4}$	$\frac{\pi}{3}$	$\frac{\pi}{2}$	$\frac{2\pi}{3}$	π	$\frac{3\pi}{2}$	2π

- v) Relation between angle and time in a clock. (R is rotation.)

Min Hand	Hr Hand
1R = 360°	1R = 360°
1R = 60 min	1R = 12 Hrs
60 min = 360°	12 Hrs = 360°
1min = 6° rotation	1 Hr = 30°
	1 Hr = 60^l
	60 min = 30^l
	1 min = $\frac{1^\circ}{2}$

The word 'minute' is used for time measurement as well as 60^{th} part of degree of angle.

- vi) Please note that "minute" in time and "minute" as a fraction of degree angle are different.

SOLVED EXAMPLES

Ex. 1) Convert the following degree measures in the radian measures.

- i) 70° ii) -120° iii) $\left(\frac{1}{4}\right)^\circ$

Solution : We know that $\theta^\circ = \left(\theta \times \frac{\pi}{180}\right)^c$

$$\text{i) } 70^\circ = \left(70 \times \frac{\pi}{180}\right)^c$$

$$\therefore 70^\circ = \left(\frac{7\pi}{18}\right)^c$$

$$\text{ii) } -120^\circ = -\left(120 \times \frac{\pi}{180}\right)^c$$

$$\therefore -120^\circ = -\left(\frac{2\pi}{3}\right)^c$$

$$\text{iii) } \left(\frac{1}{4}\right)^\circ = \left(\frac{1}{4} \times \frac{\pi}{180}\right)^c$$

$$\therefore \left(\frac{1}{4}\right)^\circ = \left(\frac{\pi}{720}\right)^c$$

Ex. 2) Convert the following radian measures in the degree measures.

i) $\left(\frac{7\pi}{3}\right)^c$ ii) $\left(\frac{-\pi}{18}\right)^c$ iii) $\left(\frac{4}{7}\right)^c$

Solution : We know that $\theta^c = \left(\theta \times \frac{180}{\pi}\right)^\circ$

i) $\left(\frac{7\pi}{3}\right)^c = \left(\frac{7\pi}{3} \times \frac{180}{\pi}\right)^\circ$
 $\therefore \left(\frac{7\pi}{3}\right)^c = 420^\circ$

ii) $\left(\frac{-\pi}{18}\right)^c = \left(\frac{-\pi}{18} \times \frac{180}{\pi}\right)^\circ$
 $\therefore \left(\frac{-\pi}{18}\right)^c = -10^\circ$

Note that,

$$180^\circ = \pi^c$$

Hence,

$$1^\circ = \left(\frac{\pi}{180}\right)^c, \quad 1^c = \left(\frac{180}{\pi}\right)^\circ$$

iii) $\left(\frac{4}{7}\right)^c = \left(\frac{4}{7} \times \frac{180}{\pi}\right)^\circ$
 $\therefore \left(\frac{4}{7}\right)^c = \left(\frac{720}{7\pi}\right)^\circ = \left(\frac{360}{11}\right)^\circ$

Ex. 3) Express the following angles in degrees, minutes and seconds.

i) 74.87° ii) -30.6947°

Solution:

i) $74.87^\circ = 74^\circ + 0.87^\circ$
 $= 74^\circ + (0.87 \times 60)'$
 $= 74^\circ + (52.2)'$
 $= 74^\circ 52' + 0.2'$

$$= 74^\circ 52' + (0.2 \times 60)''$$

$$= 74^\circ 52' 12''$$

ii) $-30.6947^\circ = -[30^\circ + 0.6947^\circ]$
 $= -[30^\circ + (0.6947 \times 60)']$
 $= -[30^\circ + 41.682']$
 $= -[30^\circ + 41'(0.682 \times 60)'']$
 $= -[30^\circ 41' 40.92'']$
 $= -30^\circ 41' 41''$ approximately

Ex. 4) The measures of the angles of the triangle are in A. P. The smallest angle is 40. Find the angles of the triangle in degree and in radians.

Solution : Let the angles of the triangle be $a - d, a, a + d$ in degrees.

$$\therefore a - d + a + a + d = 180^\circ$$

$$\therefore 3a = 180^\circ$$

$$\therefore a = 60^\circ$$

Also, smallest angle

$$= 40^\circ$$

$$\therefore a - d = 40^\circ$$

$$\therefore 60^\circ - d = 40^\circ$$

$$\therefore 60^\circ - 40^\circ = d$$

$$\therefore d = 20^\circ$$

$$\text{Now, } a + d = 60^\circ + 20^\circ = 80^\circ$$

Hence the angles are $40^\circ, 60^\circ, 80^\circ$

if they are $\theta_1^c, \theta_2^c, \theta_3^c, 40^\circ = \theta_1^c$, then $\frac{40}{180} = \frac{\theta_1}{\pi}$ so that $\theta_1 = \frac{2\pi^c}{9}$ $\theta_2 = \frac{60}{180} \times \pi = \frac{\pi^c}{3}$
 $= \frac{80}{180} \pi = \frac{4}{9} \pi^c$

Hence the angles are $\frac{2\pi^c}{9}, \frac{\pi^c}{3}$ and $\frac{4\pi^c}{9}$.

The angles of a triangle in degrees are 40° , 60° and 80° and in radians $\frac{2\pi^c}{9}$, $\frac{\pi^c}{3}$ and $\frac{4\pi^c}{9}$

Ex. 5) The difference between two acute angles of a right angled triangle is $\frac{7\pi^c}{30}$.

Find the angles of the triangle in degrees.

Solution : Let x and y be the acute angles of a triangle in degrees.

$$\begin{aligned} \text{Here, } x - y &= \frac{7\pi^c}{30} = \left(\frac{7\pi}{30} \times \frac{180}{\pi} \right)^\circ \\ &= 42^\circ \end{aligned}$$

$$\therefore x - y = 42^\circ \dots\dots\dots \text{(I)}$$

The triangle is right angled.

$$\therefore x + y = 90^\circ \dots\dots\dots \text{(II)}$$

adding, (I) + (II),

$$\text{we get } x - y + x + y = 42^\circ + 90^\circ$$

$$\therefore 2x = 132^\circ$$

$$\therefore x = 66^\circ$$

Put in (I)

$$66^\circ - y = 42^\circ \quad \therefore 66^\circ - 42^\circ = y$$

$$\therefore y = 24^\circ$$

\therefore The angles of a triangle are 66° , 90° and 24° .

Ex. 6) One angle of a quadrilateral is $\frac{2\pi}{9}$

radian and the measures of the other three angles are in the ratio 3:5:8, find their measures in degree.

Solution : The sum of angles of a quadrilateral is 360° .

$$\begin{aligned} \text{One of the angles is given to be } \left(\frac{2\pi}{9} \right)^c &= \\ \left(\frac{2\pi}{9} \times \frac{180}{\pi} \right)^\circ &= 40^\circ \end{aligned}$$

\therefore Sum of the remaining three angles is $360^\circ - 40^\circ = 320^\circ$

Since these three angles are in the ratio 3:5:8.

\therefore Degree measures of these angles are $3k$, $5k$, $8k$, where k is constant.

$$\therefore 3k + 5k + 8k = 320^\circ$$

$$\therefore 16k = 320^\circ$$

$$\therefore k = 20^\circ$$

\therefore The measures of three angles are

$$(3k)^\circ = (3 \times 20)^\circ = 60^\circ$$

$$(5k)^\circ = (5 \times 20)^\circ = 100^\circ$$

and $(8k)^\circ = (8 \times 20)^\circ = 160^\circ$

Ex. 7) Find the number of sides of a regular polygon if each of its interior angle is

$$\left(\frac{4\pi}{5} \right)^c.$$

Solution:

Let the number of sides be 'n'.

$$\begin{aligned} \text{each interior angle} &= \frac{4\pi^c}{5} \\ &= \left(\frac{4\pi^c}{5} \times \frac{180}{\pi} \right)^\circ = 144^\circ \end{aligned}$$

$$\text{Exterior angle} = 180^\circ - 144^\circ = 36^\circ$$

$$\therefore \left(\frac{360}{n} \right)^\circ = 36^\circ$$

$$\therefore n = \frac{360}{36}$$

$$\therefore n = 10$$

\therefore number of sides of the regular polygon is 10.

Ex. 8) Find the angle between hour hand and minute hand of a clock at

- i) Quarter past five
- ii) Quarter to twelve

Solution :

- 1) When a hour hand moves from one clock mark to the next one, it turns through an angle of $\frac{360^\circ}{12} = 30^\circ$.

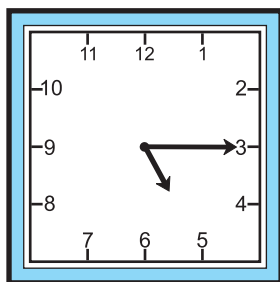

Fig. 1.14

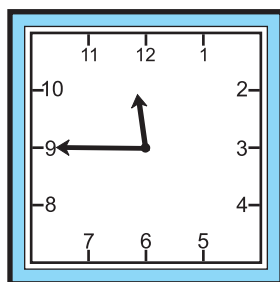

Fig. 1.15

At quarter past 5, minute hand is pointing to 3. Hour hand has gone past 5. So the angle between them is more than 60° . In one minute hour hand turns through $\frac{1^\circ}{2}$ hence in 15 minutes it has turned through $\left(\frac{15}{2}\right)^\circ = 7.5^\circ$. Thus the angle between the hands is equal to $60^\circ + 7.5^\circ = 67.5^\circ$.

ii) At quarter to twelve, minute hand is pointing to 9, hour hand is between 11 and 12 though it is nearer 12. It will take 15 minutes i.e. 7.5° to reach 12.

\therefore the angle between the hands is equal to $90^\circ - 7.5^\circ = 82.5^\circ$.

Note:

In degrees	0°	30°	45°	60°	90°	180°	270°	360
In radians	0^c	$\frac{\pi^c}{6}$	$\frac{\pi^c}{4}$	$\frac{\pi}{3}$	$\frac{\pi}{2}$	π^c	$\frac{3\pi}{2}$	$2\pi^c$

EXERCISE 1.1

Q.1 A) Determine which of the following pairs of angles are co-terminal.

- i) $210^\circ, -150^\circ$ ii) $360^\circ, -30^\circ$
 iii) $-180^\circ, 540^\circ$ iv) $-405^\circ, 675^\circ$
 v) $860^\circ, 580^\circ$ vi) $900^\circ, -900^\circ$

B) Draw the angles of the following measures and determine their quadrants.

- i) -140° ii) 250° iii) 420° iv) 750°
 v) 945° vi) 1120° vii) -80° viii) -330°
 ix) -500° x) -820°

Q.2 Convert the following angles in to radian.

- i) 85° ii) 250°
 iii) -132° iv) $65^\circ 30'$
 v) $75^\circ 30'$ vi) $40^\circ 48'$

Q.3 Convert the following angles in degree.

- i) $\frac{7\pi^c}{12}$ ii) $\frac{-5\pi^c}{3}$ iii) 5^c
 iv) $\frac{11\pi^c}{18}$ v) $\left(\frac{-1}{4}\right)^c$

Q.4 Express the following angles in degree, minute and second.

- i) $(183.7)^\circ$ ii) $(245.33)^\circ$ iii) $\left(\frac{1}{5}\right)^c$

Q.5 In ΔABC , if $m\angle A = \frac{7\pi^c}{36}$,

$m\angle B = 120^\circ$, find $m\angle C$ in degree and radian.

Q.6 Two angles of a triangle are $\frac{5\pi^c}{9}$ and $\frac{5\pi^c}{18}$. Find the degree and radian measure

of third angle.

Q.7 In a right angled triangle, the acute angles are in the ratio 4:5. Find the angles of the triangle in degree and radian.

Q.8 The sum of two angles is $5\pi^c$ and their difference is 60° . Find their measures in degree.

Q.9 The measures of the angles of a triangle are in the ratio 3:7:8. Find their measures in degree and radian.

Q.10 The measures of the angles of a triangle are in A.P. and the greatest is 5 times the smallest (least). Find the angles in degree and radian.

Q.11 In a cyclic quadrilateral two adjacent angles are 40° and $\frac{\pi^c}{3}$. Find the angles of the quadrilateral in degree.

Q.12 One angle of a quadrilateral has measure $\frac{2\pi^c}{5}$ and the measures of other three angles are in the ratio 2:3:4. Find their measures in degree and radian.

Q.13 Find the degree and radian measure of exterior and interior angle of a regular
 i) Pentagon ii) Hexagon
 iii) Septagon iv) Octagon

Q.14 Find the angle between hour-hand and minute-hand in a clock at
 i) ten past eleven
 ii) twenty past seven
 iii) thirty five past one
 iv) quarter to six
 v) 2:20 vi) 10:10

Let's Understand

1.2 ARC LENGTH AND AREA OF A SECTOR:-

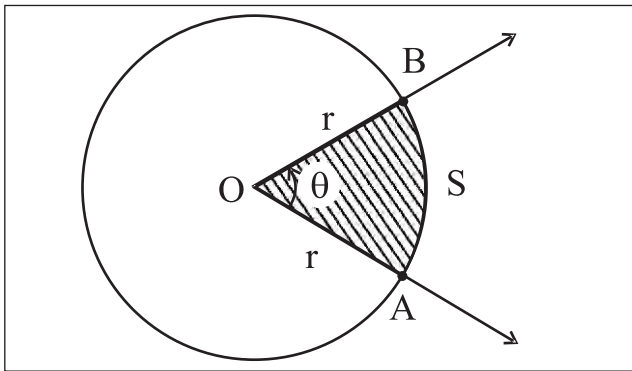

Fig. 1.16

The area A of a sector is in the proportion of its central angle θ .

If the central angle θ is in radian,

$$\frac{\theta}{2\pi} = \frac{A}{\text{Area of the circle}}$$

$$\therefore \frac{\theta}{2\pi} = \frac{A}{\pi r^2}$$

$$\therefore A = \frac{\theta r^2}{2} = \frac{1}{2} r^2 \theta$$

The arc length S of a sector is in the proportion of its central angle. If the central angle is θ radians.

$$\frac{\theta}{2\pi} = \frac{S}{\text{circumference of the circle}}$$

$$\therefore \frac{\theta}{2\pi} = \frac{S}{2\pi r}$$

$$\therefore S = r\theta.$$

SOLVED EXAMPLES

Ex. 1) The diameter of a circle is 14 cm. Find the length of the arc, subtending an angle of 54° at the centre.

Solution : Here diameter = 14 cm

$$\therefore \text{Radius} = r = 7 \text{ cm}$$

$$\theta^c = \left(54 \times \frac{\pi}{180}\right)^c = \left(\frac{3\pi}{10}\right)^c$$

To find s, we know that $s = r\theta$

$$= 7 \times \frac{3\pi}{10} = \frac{7 \times 3}{10} \times \frac{22}{7} = \frac{66}{10}$$

$$\therefore \text{arc length} = 6.6 \text{ cm}$$

Ex. 2) In a circle of radius 12 cms, an arc PQ subtends an angle of 30° at the centre. Find the area between the arc PQ and chord PQ.

Solution :

$$r = 12\text{cms,}$$

$$\theta^c = 30^\circ$$

$$= \left(30 \times \frac{\pi}{180}\right)^c$$

$$\theta = \frac{\pi^c}{6}$$

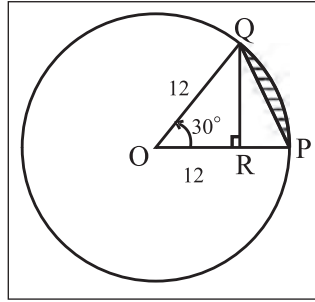

Fig. 1.17

$$\begin{aligned} \text{Area of sector OPQ} &= \frac{1}{2}r^2\theta \\ &= \frac{1}{2} \times 12 \times 12 \times \frac{\pi}{6} \\ &= 12\pi \text{ sq.cm. (1)} \end{aligned}$$

$$\text{Draw } QR \perp OP, \quad \therefore \sin 30^\circ = \frac{QR}{12}$$

$$\therefore QR = 12 \times \frac{1}{2} = 6 \text{ cms}$$

= Height of Δ OPQ

$$\text{Area of } \Delta \text{ OPQ} = \frac{1}{2} \times \text{base} \times \text{height}$$

$$= \frac{1}{2} \times 12 \times 6$$

$$= 36 \text{ sq.cm(2)}$$

By (1) and (2),

$$\begin{aligned} \text{Required Area} &= A(\text{Sector OPQ}) - A(\Delta \text{OPQ}) \\ &= (12\pi - 36)\text{sq.cm.} \\ &= 12(\pi - 3)\text{sq.cm} \end{aligned}$$

Ex. 3) The area of a circle is 225π sq. cm. Find the length of its arc subtending an angle of 120° at the centre. Also find the area of the corresponding sector.

Solution : Let 'r' be the radius of a circle whose

area is 225π sq. cm.

$$\therefore \pi r^2 = 225\pi$$

$$\therefore r^2 = 225$$

$$\therefore r = 15 \text{ cm.}$$

$$\theta^c = 120^\circ = \left(120 \times \frac{\pi}{180}\right)^c = \frac{2\pi^c}{3}$$

To find s and A.

$$\text{We know that } s = r\theta \text{ and } A = \frac{1}{2}r^2\theta$$

$$\therefore s = 15 \times \frac{2\pi}{3} = 10\pi \text{ and}$$

$$A = \frac{1}{2} \times 15 \times 15 \times \frac{2\pi}{3} = 75\pi$$

$$\therefore s = 10\pi \text{ cm and } A = 75\pi \text{ sq.cm.}$$

Ex. 4) The perimeter of a sector is equal to half of the circumference of a circle. Find the measure of the angle of the sector at the centre in radian.

Solution : Let r be the radius of a circle.

Perimeter of a sector = half of the circumference

$$\therefore l(OA) + l(OB) + l(\text{arc APB}) = \frac{1}{2}(2\pi r)$$

$$\therefore r + r + r\theta = \pi r$$

$$2r + r\theta = \pi r$$

$$\therefore 2 + \theta = \pi$$

$$\therefore \theta = (\pi - 2)^c$$

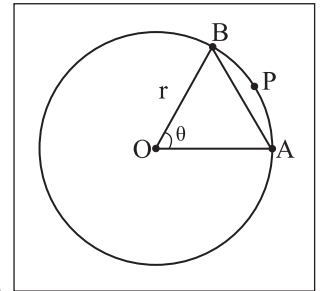

Fig. 1.18

Ex. 5) A pendulum of length 21cm oscillates through an angle of 36° . Find the length of its path.

Solution : Here r = 21 cm

$$\theta = 36^\circ = \left(36 \times \frac{\pi}{180}\right)^c = \frac{\pi^c}{5}$$

Length of its path =

$$l(\text{arc AXB})$$

$$= s = r\theta$$

$$= 21 \times \frac{\pi}{5}$$

$$= \frac{21}{5} \times \frac{22}{7} = \frac{66}{5}$$

$$\text{Length of path} = 13.2 \text{ cm}$$

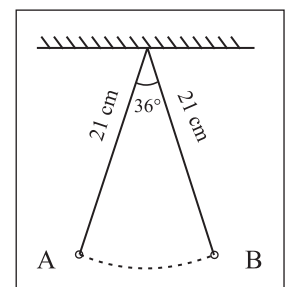

Fig. 1.19

Ex. 6) ABCDEFGH is a regular octagon inscribed in a circle of radius 9cm. Find the length of minor arc AB.

Solution : Here $r = 9\text{cm}$

$$\theta = \frac{360^\circ}{8} = 45^\circ = \frac{\pi^c}{4}$$

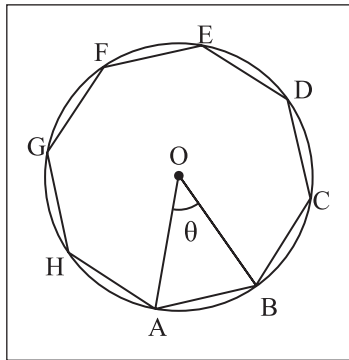

Fig. 1.20

$$\begin{aligned} l(\text{minor arc AB}) &= S \\ &= r\theta \\ &= 9\left(\frac{\pi}{4}\right)\text{cm} \end{aligned}$$

EXERCISE 1.2

- (1) Find the length of an arc of a circle which subtends an angle of 108° at the centre, if the radius of the circle is 15 cm.
- (2) The radius of a circle is 9 cm. Find the length of an arc of this circle which cuts off a chord of length, equal to length of radius.
- (3) Find the angle in degree subtended at the centre of a circle by an arc whose length is 15 cm, if the radius of the circle is 25 cm.
- (4) A pendulum of length 14 cm oscillates through an angle of 18° . Find the length of its path.
- (5) Two arcs of the same lengths subtend angles of 60° and 75° at the centres of two circles. What is the ratio of radii of two circles ?
- (6) The area of a circle is 25π sq.cm. Find the length of its arc subtending an angle of 144° at the centre. Also find the area of the corresponding sector.
- (7) OAB is a sector of the circle having centre at O and radius 12 cm. If $m\angle AOB = 45^\circ$, find the difference between the area of sector OAB and triangle AOB.
- (8) OPQ is the sector of a circle having centre at O and radius 15 cm. If $m\angle POQ = 30^\circ$, find the area enclosed by arc PQ and chord PQ.
- (9) The perimeter of a sector of the circle of area 25π sq.cm is 20 cm. Find the area of the sector.
- (10) The perimeter of the sector of the circle of area 64π sq.cm is 56 cm. Find the area of the sector.



Let's Remember

- If an angle is r radians and also θ degrees then $\frac{r}{\pi} = \frac{\theta}{180^\circ}$
- $\theta^\circ = \left(\theta \times \frac{\pi}{180}\right)^c$, $1^\circ = (0.01745)^c$
- $\theta^c = \left(\theta \times \frac{180}{\pi}\right)^\circ$, $1^c = 57^\circ 17' 48''$
- Arc length = $s = r\theta$. θ is in radians.
- Area of a sector $A = \frac{1}{2}r^2\theta$, where θ is in radians.
- Two angles are co-terminal if and only if the difference of their measures is an integral multiple of 360.
- Exterior angle of a regular polygon of n sides = $\left(\frac{360}{n}\right)^\circ$
- In one hour, hour's hand covers 30° and a minutes hand covers 360° .

- In 1 minute, hour hand turns through $\left(\frac{1}{2}\right)^\circ$ and minute hand turns through 6° .

MISCELLANEOUS EXERCISE - 1

I Select the correct option from the given alternatives.

- $\left(\frac{22\pi}{15}\right)^\circ$ is equal to
A) 246° B) 264° C) 224° D) 426°
- 156° is equal to
A) $\left(\frac{17\pi}{15}\right)^\circ$ B) $\left(\frac{13\pi}{15}\right)^\circ$ C) $\left(\frac{11\pi}{15}\right)^\circ$
D) $\left(\frac{7\pi}{15}\right)^\circ$
- A horse is tied to a post by a rope. If the horse moves along a circular path, always keeping the rope tight and describes 88 meters when it traces the angle of 72° at the centre, then the length of the rope is
A) 70 m. B) 55 m. C) 40 m. D) 35 m.
- If a 14cm long pendulum oscillates through an angle of 12° , then find the length of its path.
A) $\frac{13\pi}{14}$ B) $\frac{14\pi}{13}$ C) $\frac{15\pi}{14}$ D) $\frac{14\pi}{15}$
- Angle between hands of a clock when it shows the time 9.45 is
A) $(7.5)^\circ$ B) $(12.5)^\circ$ C) $(17.5)^\circ$ D) $(22.5)^\circ$
- 20 meters of wire is available for fencing off a flower-bed in the form of a circular sector of radius 5 meters, then the maximum area (in sq. m.) of the flower-bed is
A) 15 B) 20 C) 25 D) 30

- If the angles of a triangle are in the ratio 1:2:3, then the smallest angle in radian is
A) $\frac{\pi}{3}$ B) $\frac{\pi}{6}$ C) $\frac{\pi}{2}$ D) $\frac{\pi}{9}$
- A semicircle is divided into two sectors whose angles are in the ratio 4:5. Find the ratio of their areas?
A) 5:1 B) 4:5 C) 5:4 D) 3:4
- Find the measure of the angle between hour-hand and the minute hand of a clock at twenty minutes past two.
A) 50° B) 60° C) 54° D) 65°
- The central angle of a sector of circle of area 9π sq.cm is 60° , the perimeter of the sector is
A) π B) $3+\pi$ C) $6+\pi$ D) 6

II Answer the following.

- Find the number of sides of a regular polygon if each of its interior angle is $\frac{3\pi}{4}$.
- Two circles, each of radius 7 cm, intersect each other. The distance between their centres is $7\sqrt{2}$ cm. Find the area of the portion common to both the circles.
- ΔPQR is an equilateral triangle with side 18 cm. A circle is drawn on the segment QR as diameter. Find the length of the arc of this circle within the triangle.
- Find the radius of the circle in which central angle of 60° intercepts an arc of length 37.4 cm.

- 5) A wire of length 10 cm is bent so as to form an arc of a circle of radius 4 cm. What is the angle subtended at the centre in degrees ?
- 6) If two arcs of the same length in two circles subtend angles 65° and 110° at the centre. Find the ratio of their radii.
- 7) The area of a circle is 81π sq.cm. Find the length of the arc subtending an angle of 300° at the centre and also the area of the corresponding sector.
- 8) Show that minute hand of a clock gains $5^\circ 30'$ on the hour hand in one minute.
- 9) A train is running on a circular track of radius 1 km at the rate of 36 km per hour. Find the angle to the nearest minute, through which it will turn in 30 seconds.
- 10) In a circle of diameter 40 cm, the length of a chord is 20 cm. Find the length of minor arc of the chord.
- 11) The angles of a quadrilateral are in A.P. and the greatest angle is double the least. Find angles of the quadrilateral in radian.

